

---

## OPTIMAL ENERGY MANAGEMENT OF MICROGRIDS INTEGRATED WITH RENEWABLE ENERGY SOURCES

**#1 K. VAMSHI KRISHNA, Associate Professor,**

**#2 T. VIJAY KUMAR, Assistant Professor,**

**#3 REKALA SRI VYSHNAVI, B.Tech Student,**

**#4 REGUNTA GOURI CHANDANA, B.Tech Student,**

**#5 PAVURALA SAGAR, B.Tech Student,**

**#6 JANJARLA SRIRAM, B.Tech Student,**

*Department of Electrical and Electronics Engineering,*

**TRINITY COLLEGE OF ENGINEERING AND TECHNOLOGY, PEDDAPALLY, TG.**

**ABSTRACT:** The objective of this project is to create a power management system that regulates the energy requirements and transmission of a completely integrated green energy system, with a particular emphasis on solar and wind energy. Resilient control and storage mechanisms are essential for the optimal and efficient operation of a system. Indirect vector control with droop compensation can be employed to modulate the voltage and frequency of the line-side converter. Frequency oscillations are induced by fluctuations in battery energy, particularly during the charging and discharging process. Wind energy is not a factor in the operation of the system. A comprehensive system-wide management algorithm is implemented by an Intelligent Power Management System (IPMS) to regulate fluctuations in power supply and demand. The assessment of a wide range of power supply and demand is facilitated by a power system. Simulations suggest that the IPMS can meet demand by integrating batteries and intermittent renewable energy sources, including solar and wind power.

**Keywords:** *Control system, IPMS, PV, and Systems Power Energy.*

---

### 1. INTRODUCTION

Diesel engines are the primary source of electricity in a multitude of rural areas. These energy sources are expensive and spread swiftly. In order to effectively meet the demands of the population and address these challenges, it is imperative that we substantially increase the production of electricity in the region. A self-sufficient wind turbine is a component of the

author's photovoltaic system. Substantial storage and appropriate power electronics are necessary for autonomous devices that depend on a single energy source. This is a requirement for the majority of solar battery adapters. Its intricate design leads to an increase in weight and higher expenses. The efficacy of the system is reduced by the phased transition. The incorporation of a variety of hybrid power sources improves the reliability of the system and reduces the BES. Solar and wind energy are the most effective sources of hybridization. Annual behavioral tendencies are meticulously documented. Display benevolence. It was independently introduced by multiple authors. Leverage this synergy by implementing a hybrid solar-wind system. Compact turbines are the primary application for permanent magnet synchronous generators. A PMSG can be integrated into even the most expensive devices without the necessity of gearing. The absence of pace limitations in Maximum Power Point Tracking enables SCIG to produce machines that are more cost-effective than those of its competitors.

SCIG engines were implemented by additional authors to develop hybrid systems that combine wind and solar energy. In order to implement speed control, a thorough conversion is necessary. The authors provide a comprehensive examination of solar and self-sufficient applications. Applications in the exploitation of industrial wind energy are demonstrated by dual power induction generators. DFIG Variable Speed Processes can be powered by low-power converters. This demonstrates a microgrid renewable energy system that is propelled by wind and illuminated by solar energy. Diode properties in a solar system with a variety of DC-DC converter inputs and optimal power locations. We investigate the simultaneous utilization of power sources and the efficiency of DC converters.

Batteries and photovoltaic solar arrays are frequently implemented to modulate the output of energy from a variety of sources and to supply consistent energy in the appropriate form. It is conceivable that three DC-to-DC converters were implemented. In order to optimize energy density and minimize expenses, this investigation implements a remote DC/DC 3-port converter (TPC) in photovoltaic systems. In order to modulate energy levels in response to fluctuations in solar, wind, and freight inputs, the hybrid device is equipped with a battery energy storage system (BESS).

A DC-DC boost converter regulates low-voltage photovoltaic systems and battery backups while modifying the output direct current voltage to optimize solar photovoltaic energy extraction. Disruption and high-voltage advantage converters are employed to achieve this. This mitigates partial shadowing and reduces parasitic capacitance at the photovoltaic source.

A physical interface is not required to connect multiple battery units in series. This method extends the lifespan of the battery by reducing the risk of overcharging and discharging.

Utilizing MATLAB/Simulink, the efficacy of the proposed manipulation techniques is evaluated in real time for linear, nonlinear, unstable, and stable masses and environmental variables. Modest wind turbines (200 kW power plants) are essential in the dispersed generation segment of the wind power industry due to their diminutive size. Your power sources may be upgraded as necessary as a result of their shared power connection.

The development of discharge, active, and reactive power controls has garnered attention. Examine a hybrid power system that is self-contained and combines solar and wind energy to improve energy conversion and reliability. The results indicated that the system was capable of precisely adjusting the energy supply in response to fluctuations in demand and weather.

The hybrid system's AC output voltage can be precisely adjusted in terms of amplitude and phase. A nearly 25% increase in global energy usage by 2040 is predicted by numerous studies, which emphasize microgrids (MG). It is anticipated that renewable energy will comprise 40% of the world's energy consumption. The discrepancy between supply and demand is the primary reason for the unreliability of renewable energy sources.

The evaluation of energy systems, energy storage, distributed generation (DG), and renewable energy sources improves consumer accessibility. Renewable sources of energy are utilized. The temporal variability and nonlinearity of photovoltaic direct current microgrids are significant. Conventional dual voltage and current regulation systems that employ PI controllers are unable to regulate variations in DC bus voltage, despite their improved dynamic reactivity. The Droop property regulates the voltage and frequency of roadside converters through diagonal vector control.

It regulates the rates of charging and discharging by modifying the frequency reference in accordance with the battery's energy level. This procedure is effective, despite the absence of nearby wind energy sources. Tracking the maximum power point is indispensable for all solar and wind energy systems. The battery is recharged by the device's power source, eliminating the need for electricity. Diverse scenarios are addressed by MATLAB or Simulink models.

## **2. TOPOLOGY STRUCTURE**

The micro lattice schematic of the REGS device is depicted in Figure 1. The strategy concentrates on regions with a large population density. The averages are 5 kW and 15 kW. REGS is capable of regulating 15 kW of wind energy upon the installation of solar modules.

The incubator has the capacity to operate at 20% capacity for a single day, which will provide assistance to both power units. The system will be protected by the circuit breaker in the event of insufficient wind energy resources, as demonstrated. The high-voltage photovoltaic system, which accumulates energy in batteries, is interconnected with the current control side RSC and LSC. The voltage and cycle frequency of the machine are regulated by the LSC. Wind energy is captured by DFIG rotors. The full extent of mechanical potential is

$$P_m = 0.5 C_p \pi r^2 \rho V_w^3 \quad (1)$$

$V_w$  and  $r$  are the wind speed and radius in proximity to the wind machine. At a wind speed of 12 m/s, the generator in the configuration is capable of producing 17 kW. External current powers the stator and rotor. The DFIG clearance ( $P_{ag}$ ) grade is influenced by the inability to account for losses at optimal wind speed. The unit's electrical power is at risk due to the air gap's utmost entrance power. The RSC is the source of all magnetic power produced by the wind rotor. 15 kW of wind energy can be converted to electricity with an adequate DFIG capacity.

$$P_e = P_{ag} / (1 + |S_{pmax}|) \quad (2)$$

The LSC, load, and stator poles are connected by a diagonal transformer. The LSC functions as the neutral in single-phase applications that operate at 415 volts. The maximum voltage on the low-voltage side of the zigzag, denoted as  $V_{rmax}$ , is determined. As a result, the transformer's stator, high-voltage coil, and the voltage ratio of 415/125 V for the load remain constant. The capacitor  $C_b$  can be directly energized by the internal resistance  $R_{in}$ . A link to the series has been provided. The battery is capable of self-discharge due to the presence of an independent RB resistance. Circuit cells are denoted by DC and open circuit voltages ( $V_{OCC}$ ). NC VDCM is equivalent to  $V_{OCC} \cdot 3$ . RC filters with a stator connection attenuate voltage fluctuations and frequencies that are below the fundamental frequency. The transition frequency must be decreased by fifty percent.

|   |   |
|---|---|
| Open circuit voltage of PV cell, $V_{oc}$     | 0.64 V                                  |
| Open circuit voltage of a module ( $v_{oc}$ ) | 23.04V                                  |
| MPP voltage of PV cell, $V_{mpc}$             | 0.5223V                                 |
| MPP voltage of module ( $V_{mp}$ )            | 18.83V                                  |
| Short circuit current of module ( $I_{sc}$ )  | 8.69A                                   |
| MPP current of module ( $I_{mp}$ )            | 8.04A                                   |
| A Module Power Rating $\mu I_{sc} \mu V_{oc}$ | 151Wp                                   |
| Pv modules in the solar block                 | 0.04%/oC                                |
| String open circuit voltage (SOCV)            | -0.36%/oC                               |
|   | 11 strings each are having 9 PV modules |
|   | 207.36V                                 |

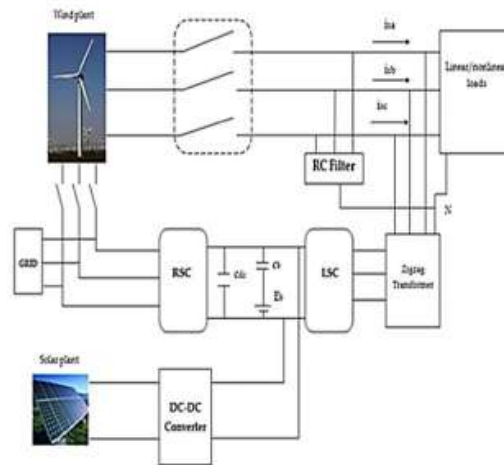

Figure 1: Schematic diagram of a hybrid microgrid of renewable energy sources

### 3. CONTROL STRATEGY

Utilizing integrated SMPPT technology, this DC-DC converter is designed for solar systems with variable resistance. The solar system's operation is facilitated by the precise calibration of SMPPT to the Maximum Power Point (MPP). In the absence of wind, onshore wind turbines are only required to produce energy for 60–70% of the time. Figure 2 illustrates the control strategy.  $I^*_{qs}$  is composed of two components. While the wind turbine is operational, the power of the DFIG is displayed in  $i_{qs1}$ .  $i_{qs2}$  is initiated by the detachment of the DFIG stator from the load terminal. Reactive power, or DC  $I^*_{ds}$ , is necessary for the connection of the generator and filter. The  $I^*_{qs}$  and  $I^*_{ds}$  values are instrumental in the stabilization of voltage and frequency during indirect vector control, as further explained below.

$$I^*_{ds} = I_{ds(k-1)} + K_{pv}(V_{err(k)} - V_{err(k-1)}) + K_{iv} \int V_{err(k)} dt \quad (3)$$

$$I^*_{qs} = I^*_{qs1} + I^*_{qs2} \quad (4)$$

Turbine speed is regulated by the RSC to guarantee that the device operates within the MPP. Additionally, it powers the engine's magnets. The transitional perspective of h slip, direct rotor currents  $I_{qr}$  and  $I_{dr}$ , and orthogonal manipulation are all illustrated in Figure 3. The direct axis current ( $I_{dr}$ ) is connected to the magnetization current of the device through Field Oriented Vector Control. The proportional-integral (PI) speed controller's advantages are represented by the constants  $K_p$  and  $K_i$ . The regulation of MPP and the mitigation of voltage disruptions are facilitated by fluctuations in wind speed during periods of high output and low demand. The adequacy cost can be estimated using  $k_1$  and  $k_2$  circuits.

$$\theta_{slip} = \int_0^t (w_e^* - \frac{p}{2} w_r) dt$$

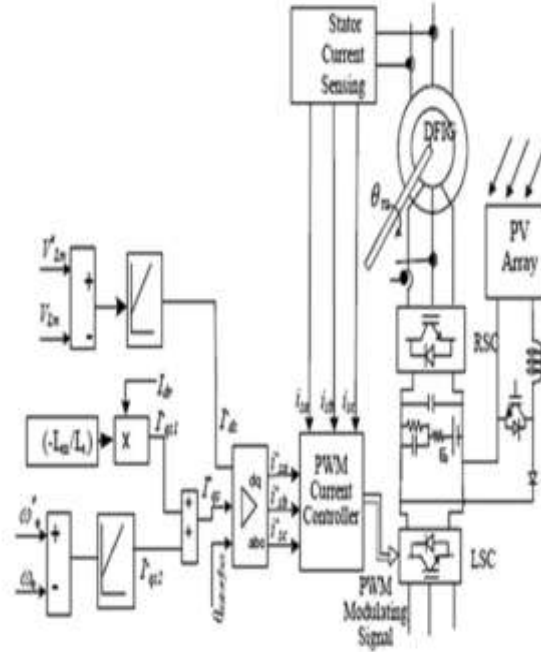

Figure 2: Control strategy of LSC

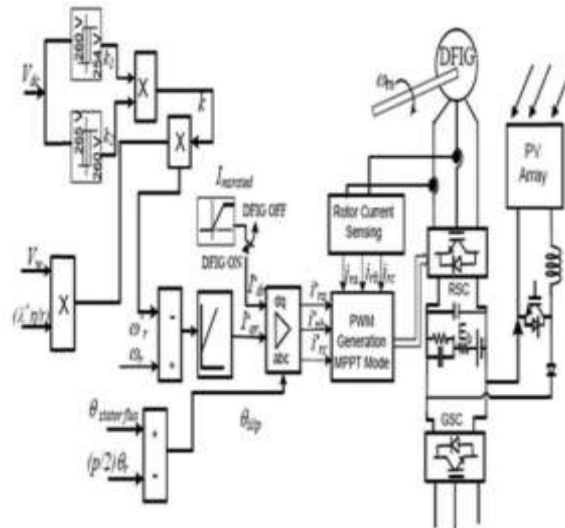

Figure 3: Control strategy of RSC

## 4. SIMULATION RESULTS

### Case-A: System performance at cut in and cut out of wind power

The 10 kW and 6 kVAR loads are depicted in Figure 4 prior to initiation. Any device or system that is powered by solar or wind energy. At  $t = 0.05$  s, the wind power generator operates at a velocity of 7 m/s. As a result, the electrical output of the device will fluctuate. Windmill at a rate of 0.5 seconds. At  $t = 1.0$  seconds, the wind speed increases from 7 to 8

m/s before gradually decreasing. Improved regulation of the rotor. We used WMPPT to calculate the rotational velocity. Nevertheless, turbines terminate operation at 1.4 seconds.

### Case-B: System performances at cut in and cut out of solar power

The machine will operate at 10 kW and 6 kVAR in the absence of solar or wind energy. A solar configuration that generates 800 W/m<sup>2</sup> of illumination at  $t = 0.05$  s is depicted in Figure 5. The illumination intensity peaked at 900W/m<sup>2</sup> at  $t = 0.34$ s and subsequently declined to 800W/m<sup>2</sup> at 0.52s. The solar system suspends operations for a period of 1.08 seconds after each orientation change. The device's power output appears to be inconsistent.

### Case-C: System performances at unbalanced and nonlinear load

The tool's unbalanced nonlinear behavior is illustrated in Figure 6. In order to meet nonlinear demand, a substantial microgrid is necessary. The load is supplied with eight kilowatts of nonlinear power and two kilowatts of linear power. The community will be devoid of sections at 3.25 seconds. Analogously, the B-section burden operates at  $t = 3.46$  s. The maximal power of the device may be generated irrespective of whether the load is linear or flat.

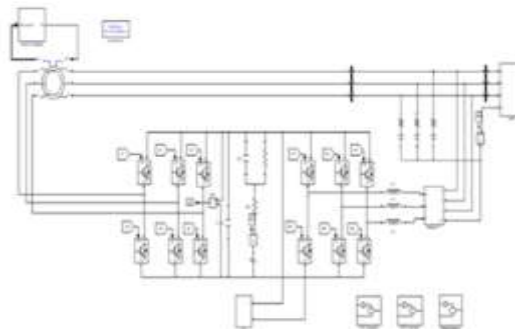

Figure 4: Performance of a system at constant load and cut-in and cut-out of wind power

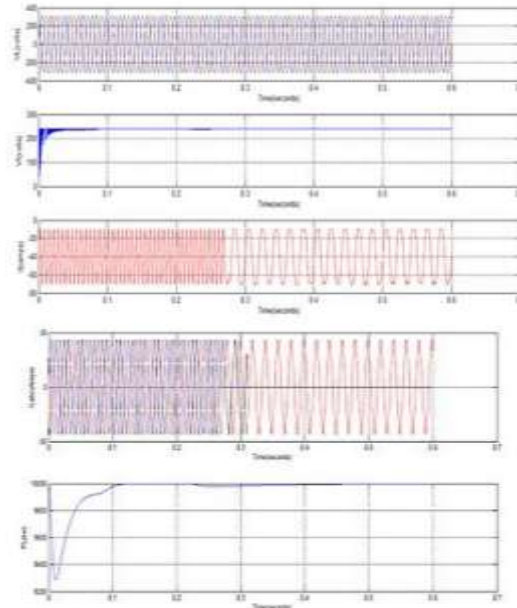

Figure 5: System performance at unbalanced and non-linear load.

## 5. CONCLUSION

A functional REGS microgrid technology was suggested. The responsibilities of the household are diminished by its isolated location. REGS utilizes apparatus designed to capture solar and wind energy to produce electricity by enhancing renewable energy sources. Solitary operation is the intended purpose of this device. Additionally, the investigation furnishes substantial sectional dimensions. It provided the system with instructions on how to adjust the input state for a variety of load profiles. Regardless of the load terminal condition, the power quality remains sufficient.

## REFERENCES:

1. B. Singh, "Implementation and control of small-scale hybrid standalone power generation system employing wind and solar energy", IEEE on ESC, vol-7, pp.1- 7, Sep 2016.
2. H.S. Athab, PV isolated three port converter and energy balancing control method for PV-battery power supply applications, IEEE Indus. Appl. 3 (2015)
3. . M. Das, "Novel high performance standalone solar PV system with high gain, high efficiency
4. DC-DC converter power stages", IEEE Indus. App, 2015

5. . N.A. Orlando, A survey of control issues in PMSG based small wind turbine systems, IEEE Trans Ind. Inf. 9 (3) (2013).
6. T. Hirose, Standalone hybrid wind-solar power generation system applying Dump power control without dump load, IEEE Trans. Ind. Electr. 59 (2) (2012).
7. Q. Zhiyuan, Coordinated control for independent wind-solar hybrid power system, APPEE Conf. (2012).
- A. Singh, “Microgrid: A review”, IJRET, vol-3, Issue-2, Feb 2014.
8. M. Lexuan, Review on control of DC microgrids and multiple microgrid clusters, IEEE J. Power Electr. (2017).
9. Y.E.G. Vera, Energy management in microgrids with renewable energy sources: a literature review, APPLSCI (2019).
- 10.S. Anand, “Renewable integration solar PV and microgrid”, Smart Grid Technologies, May 2019.