MODELING AND CONTROL OF A MICROGRID POWERED BY RENEWABLE ENERGY SOURCES

#1 KOPPULA SRINIVAS, Assistant Professor,

#2 SIDRA JABEEN, B.Tech Student,

#3 MANTHENA DILIP KUMAR, B.Tech Student,

#4 SHAIK FAREED, B.Tech Student,

#5 MATETI SAHITHI, B.Tech Student,

Department of Electrical and Electronics Engineering,

TRINITY COLLEGE OF ENGINEERING AND TECHNOLOGY, PEDDAPALLY, TG.

ABSTRACT: This research illustrates the remote operation of a hybrid sustainable aging system. The wind and the sun supply its energy. Double-fed induction generators (DFIGs) with maximum power point tracking technology convert wind energy into electrical power. Glass-like solar photovoltaic (PV) systems harness direct sunlight to produce electricity. It operates using the DFIG standard DC transit. The DC assist converter utilizes solar energy and MPPT algorithms to identify the sun's most intense rays. Energy sharing is facilitated by the DFIG's conventional DC transmission and battery storage systems. The technology is engineered to perform designated tasks for individuals and to operate in various real-world contexts. The system use external electricity to recharge batteries similarly. The voltage, repeat, and suspend functionalities of the load side converter are regulated by an adapted underhanded vector control mechanism. The battery power is considered when modifying the repeat frequency. The MATLAB Sim-Power System auxiliary reserve demonstrates the functionality of the structure under conditions of uneven weights or in the absence of solar or wind energy.

Keywords: *Renewable energy sources, solar power generation, wind power, Hybrid system, MPPT Controller, micro grid*

1. INTRODUCTION

Optimized wind-solar (PV) energy systems for management and storage can be implemented in compact structures. The regulation of the grid reliant on fossil fuels may be diminished due to the restricted scope of this region. A limited network establishes the organization's

financial authority. The developers suggest a comprehensive management method to allocate financial authority within a limited framework.

The distinctive working environment imposes no constraints on the creation of quality control and productivity frameworks. The notion of wind and sun centrality is superior to numerous other basics for universal power. Safety measures must be implemented in the control and power distribution systems. It stabilizes electricity, safeguards personnel, and prevents equipment misuse.

Traditional simultaneous machine control systems are the primary failure aid in protection theory. During the orchestration process, they disclose their security protocols. The framework is employed to evaluate novel sources of faults. The utilization of renewable energy sources influences power system failures. Security precautions implemented during orchestration may remain effective even if a renewable energy source (RES) provides only a minimal quantity of electricity.

Transmission structures may become dislodged if the expansive RES entry interferes with overcurrent transfers at distributed feeders. Numerous locations on the earth lack electricity. In regions with enhanced grid connectivity, power outages endure for fewer than 24 seconds. Biomass, wind, and solar energy are significant resources in these regions. Provided that purchasers own realistic power sources capable of precisely managing these domains, they can consistently obtain high-quality functionalities. A battery bank functions as a power supply and a storage unit for these systems.

It enables the machine to commence tasks incrementally. Implementing efficient solar and wind energy systems, along with energy storage, can reduce the power grid's demand. You can reduce your dependence on fossil fuel-driven lattice control by employing small-scale construction. Rural regions require a versatile, efficient organization and a reliable power supply; therefore, this project is essential.

For small islands globally to endure, non-renewable energy sources are essential. The cost of essential electricity increases when diesel generators and petroleum transportation are utilized. The average electricity cost in Pulau Ubin is SGD1.43 per kWh for households and SGD1.12 per kWh for enterprises, as reported by Singapore's Energy Market Authority (EMA).

Due to its contaminating influence, it is typically employed to avert occurrences. Should the transmission wires be subterranean, the expense of extending the control network from Singapore to this island would be prohibitive. Subsequently, they implemented a mixture

control system for a residence in Pulau Ubin. Cross-variation control systems with infinite urgency diminish CO2 emissions and diesel use in remote regions and islands, resulting in financial and environmental benefits.

2. PRINCIPLE AND DESIGN FOR PROPOSED SYSTEM

The proposed approach employs a perpetual mixture and an MPPT charge regulator to enhance renewable power generation. Figure 2.1 illustrates the organization of the proposed framework. The primary source of wind energy is Doubly-Fed Induction Generators (DFIGs). A circuit featuring a rectifier and lift converter, integrated with an MPPT regulator, is linked to a solar power system. The converter circuit employs the MPPT algorithm to optimize solar electricity conversion. An MPPT regulator synchronizes the output of source DC power systems.

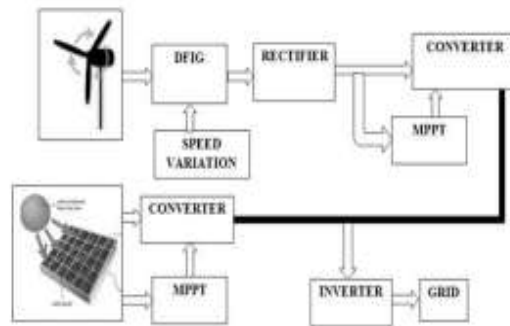

Fig.1. Block diagram of proposed system Wind Generation System

This section illustrates the application of an MPPT charge regulator and a DFIG wind generator in the context of wind energy technology. The rotor operates for a specified duration in an air zone whose thickness correlates with the wind speed and whose cross-sectional area is equivalent to its diameter. In Condition 1, power depletion is represented as energy per unit time.

$$p = \frac{1}{2} \rho A V_w^3 \tag{2.1}$$

A (m²) denotes the rotor's cross-sectional area, whereas P (W) signifies power. Temperature, pressure, altitude, and air composition all influence thickness. A and P represent the rotor's cross-sectional area in cubic meters and power in watts, respectively. Temperature, height, atmospheric pressure, and air composition all influence thickness.

$$p = \frac{1}{2} c_p \rho A V_w^3 \tag{2.2}$$

To ascertain the co-productive force, divide the released force by the available power. Force is a cofactor in the production of C_p . Condition (2.3) illustrates the streamlining force, which is contingent upon the rotor power and velocity. The breeze cannot supply wind turbines with their entire electrical needs. The rotor harnesses a portion of the engine's energy, while the turbine expels air. Condition 2 triggers the transmission condition (A1). "Cp" is an abbreviation for the co-effective force. Force co-effectiveness is the ratio of applied force to available power. The third criterion pertains to the streamlining force, which is contingent upon the rotor's strength and velocity.

$$\lambda_t = \frac{\omega r r}{V_w} \quad (2.3)$$

The symbols ω and rr represent the rotor edge radius (m) and random rotation speed (RPM), respectively. The correlation among power, power co-effectiveness, and tip speed percentage indicates that mechanical power derived from the wind reaches its maximum at a specific wind velocity. The thickness of the air layer traversed by the rotor for a specified duration is contingent upon wind velocity, with the cross-sectional area corresponding to the rotor's length. Due to the power loss, energy will be quantified per time unit. Photovoltaic (PV) technology use semiconductor materials to transform light into electricity. Light exhibits both particle and wave characteristics. A photon is the fundamental unit of light. Photons are massless entities that propagate at the speed of light. Einstein's law states that a photon's energy is contingent upon its frequency.

$$E = h\nu \quad (2.4)$$

V , h , and E represent photon energy, Planck's constant ($h = 6.626 \times 10^{-34}$ Js), and photon repetition, respectively. The power output of solar panels dictates the worth of a photovoltaic solar cell. The links may provide a quantitative overview. where $\eta = (P_{sol}/P_{el}) = (U \cdot I / E \cdot A)$ (2.5), with E representing the specific radiation power (W/m^2), A denoting the area, P_{el} as the electrical output power, P_{sol} as the solar radiation power, U as the resultant voltage, and I as the power yield. Individuals in remote regions lacking electricity or infrastructure utilize these systems. Batteries are incorporated in systems that utilize energy-management technology. The inverter can provide electricity daily to various electrical equipment and devices.

HYBRID POWER SYSTEM

To reestablish restrictions that were absent during the initial loading of the token, combination power systems employ two energy exchange devices or two energizers for an

analogous device. Crossover models encompass cost, pollution, reliability, productivity, and fuel exclusion.

SYSTEM DESIGN AND ARCHITECTURE

A solitary line graph of the proposed REGS elucidated the dimensional limitation. A rural municipality with a peak demand of 15 kW and an average demand of 5 kW is subject to identical constraints. The proposed method presumes that each board and wind turbine can regulate 15 kW. A 20% utilization threshold mechanism guarantees that the system will satisfy the town's daily requirements. If the airflow velocity is not as anticipated, utilize a three-pole circuit breaker to disconnect the assembly's wind energy supply. The battery bank connects to the RSC and LSC DC sides of the DC converter near the high-voltage side.

Utilizing RSC, the airflow imperative system sustains the optimal rotational velocity of the WMPPT. The LSC regulates the framework's voltage and frequency of repetition. A stream diagram illustrates the principal components of the system.

NEED FOR DOUBLY FED INDUCTION GENERATOR

A three-shaft breaker can sever the breeze control source from the system if the wind velocity is insufficient. The battery bank connects to the RSC and LSC DC sides of the DC converter near the high-voltage side. The WMPPT count indicates that RSC facilitates the reconfiguration of airflow dynamics to maintain its combustion velocity. The LSC regulates the system voltage and reconfigures. The critical stream DFIG is employed in wind management systems that necessitate an initial restriction, a low converter rating, and straightforward speed regulation. The rotor side converter and load side converter (LSC) in a DFIG are sequentially coupled and operate in conjunction with DC transmission. The RSC determines the maximum visible power point by adjusting the wind turbine's speed. The solar-powered photovoltaic system is linked to the DC transmission using a lift DC converter. The DC converter employs the latest S-MPPT computation. Consequently, solar-controlled energy diminishes in intensity. In the event of a low battery and the absence of a wind energy source, the battery bank may be recharged utilizing the framework control or a diesel generator connected to the same RSC. The LSC stabilizes the survey voltage and reprocesses at the PCC.

CONTROL OF DC-DC CONVERTER

In the application of SMPPT, a constant conductance regulates the DC boost converter. Solar energy is transformed into voltages akin to those of a battery by a DC boost converter. The S-MPPT optimizes solar power by adjusting the final voltage of the show.

3. SIMULATION OF PROPOSED SYSTEM

Figure 2 shows the simulation diagram for the suggested system.

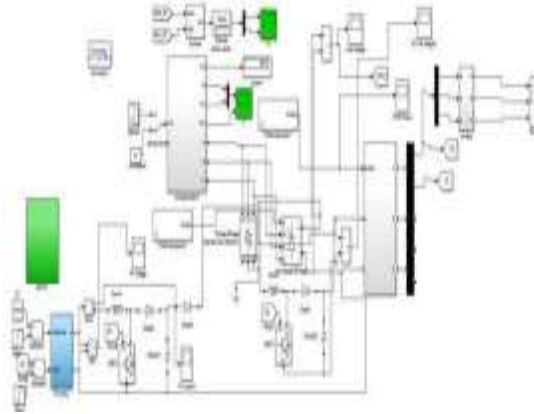

Fig.2.Simulation diagram of proposed system

Figure 3 shows a simulation diagram for the suggested solar photovoltaic generating system.

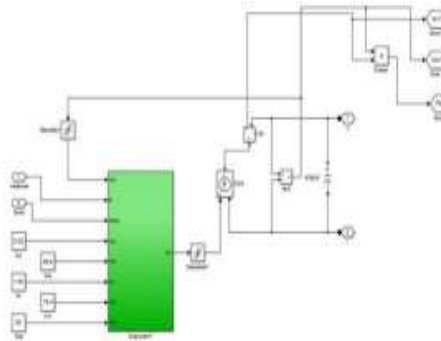

Fig.3.simulatin diagram of Solar PV system

Figure 4 shows the DFIG wind power system's simulation model.

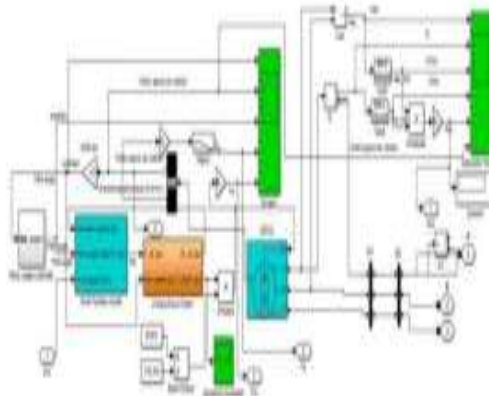

Fig.4.Wind power generation system simulation model

The Sugeno-Fis approach for putting the fuzzy algorithm into practice is shown in Figure 5.

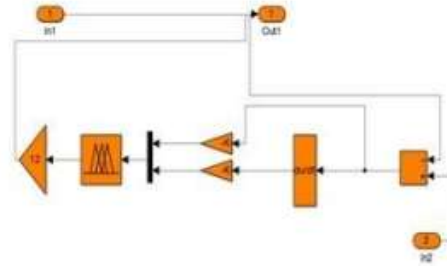

Fig.5.Fuzzy implementation in proposed system

The MATLAB simulation tool is used to implement the suggested system. The next section provides an overview and analysis of the findings.

4. SIMULATION RESULTS AND OUTPUT WAVEFORM

This section looks at the results of the reproduction that was integrated with the MATLAB simulation software.

CASE 1: POWER GENERATION WITHOUT MPPT TECHNIQUE

When the wind speed is changed and the harvest is generated, the framework's maximum speed is 15 meters per second. The voltage generated by solar photovoltaic systems is shown in Figure 6.

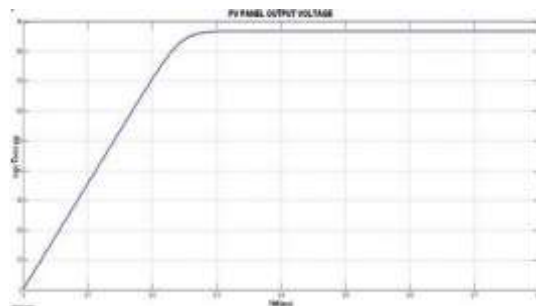

Fig.6.Solar PV output voltage waveform

Figure 7 shows the waveform of the DC output voltage generated by wind power. It displays the solar photovoltaic output voltage waveform.

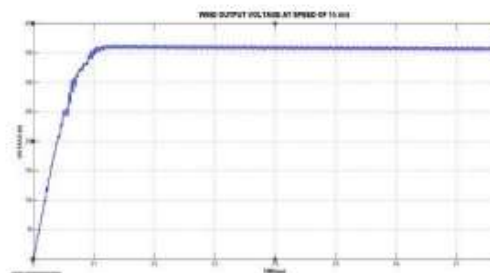

Fig.7.Wind power output voltage waveform

Figure 8 shows the DC connection voltage waveform for integrating wind and solar power sources.

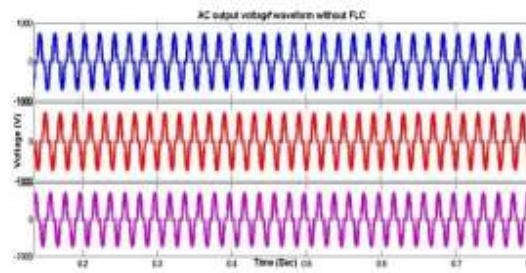

Fig.9.three phase output voltage waveform

As seen in the picture, the output has an amplitude of roughly 700 volts AC rather than being completely AC.

CASE 2: POWER GENERATION WITH FUZZY MPPT.

Using a FUZZY system to mimic the previously described system, the inverter circuit produces AC electricity using PWM. Figure 11 shows the voltage waveform associated with wind power emissions.

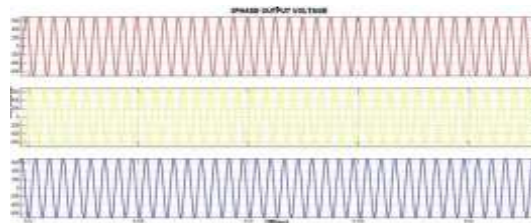

Fig.10.Three phase output voltage waveform

The comparison of examples 1 and 2 shows that the voltage waveform stays steady at about 700 volts AC, which greatly lowers wave content and aural disruptions.

CASE 3: Power age in 8 m/sec breeze speed

Before analysis, the wind speed is changed to confirm the outcome. The result stays the same, producing an AC yield waveform with a 700 volt potential. The voltage results are shown in Figure 11.

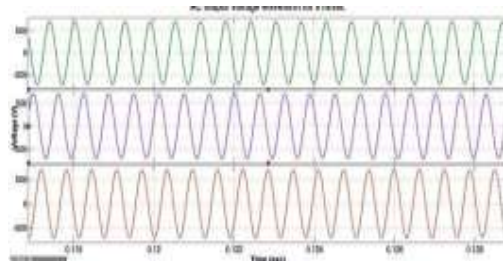

Fig.11. AC output voltage waveform in 8 m/sec

CASE 4: POWER GENERATION IN 12 m/sec

Figure 12 shows how an AC output voltage waveform is preserved at a wind speed of 12 m/sec.

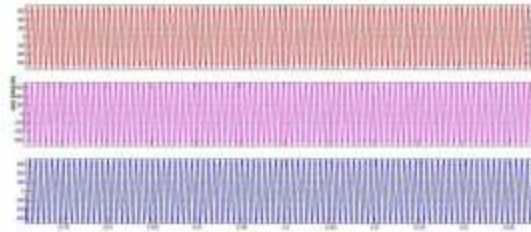

Fig.12. Three phase AC voltage output waveform with 12 m/sec wind speed

This section provides a summary of the conclusions drawn from the data gathered in each case.

5. CONCLUSION

The suggested MPPT technique is used to increase efficiency in a hybrid power generation system that is duplicated by synchronizing solar and wind cells under various conditions. As noted before, MATLAB/Simulation programming was used to construct the framework. In order to determine the expected gap between age and power diversity, this study intends to reassess the previously suggested technique across several scenarios. The intended delicate structure is made up of several waves, music, and three voltage phases. Notably, based on the waveforms and results generated in the previous section, it sustains a voltage of 700 volts AC at different velocities. In order to guarantee a constant yield, this study simulates the operating age of wind turbines that run at wind speeds of 8, 12, and 15 m/sec.

REFERENCES

1. R.G. del Valle, M. Cotorogea, B. Rabelo and W. Hofmann, On the emulation of an isolated wind energy conversion system: experimental results, Proc. IEEE Electronics, Robotics and Automotive Mechanics Conf. CERMA09, (2009), 462–467.
2. [N.A. Orlando, M. Liserre, R.A. Mastromauro and A. Dell'Aquila, A survey of control issues in PMSGbased small wind turbine system, IEEE transactions on Industrial Informatics, 9(3)(2013), 1211-1221.
3. Jeyashree Arthanareeswaran, Bavithra Karunanidhi, Sowmiya Muruganatham Subash Kumar C S, Automatic Vehicle Accident Indication and Reporting System for Road Ways Using Internet of Things International Journal of Safety and Security Engineering 11 (No. 3), pp. 269-27

4. S. Sharma and B. Singh, Asynchronous generator with battery storage for standalone wind energy conversion system, IEEE Ninth International Conference on Power Electronics and Drive Systems (PEDS), 345-350. Penava, S. Galijasevic,
5. A. Muharemovic and M. Penava, Optimal design and demonstrative application of standalone hybrid renewable energy system, IEEE International Energy Conference (ENERGYCON), (2014), 960-967.
6. N. Adhikari, B. Singh, A.L. Vyas and A. Chandra, Analysis, design and control of a standalone hybrid renewable energy conversion system, 4th IEEE International Power Electronics for Distributed Generation Systems (PEDG), (2013), 1-8.
7. Venkatesan, M., Subash Kumar, C. S., & Sathiyathan, M. (2020). A Step By Step Design of PV System: A Research Approach For Engineering Graduates. Journal on Future Engineering & Technology, 16(1). Emmanouil A. Bakirtzis and Charis Demoulias, Control of a micro grid supplied by renewable energy sources and storage batteries, XXth International Conference on Electrical Machines (ICEM), (2012), 2053-2059.
8. Chen Jian, Che Yanbo and Zao Lihua, Design and Research of Off-grid Wind-Solar Hybrid Power Generation Systems, 4th International Conference on Power Electronics Systems and Applications (PESA), (2011), 1-5.
9. Fernando Ornelas-Tellez, Optimal Control for a Renewable-energy based Micro-grid, Special session on renewable energy ROPEC, (2014).